

The Horizon 6904 RS Living Quarters scream "Take me camping." One of the smallest living quarters Sundowner offers, this all aluminum trailer is available in a 2, 3, or 4 horse. The 6904 RS comes standard with an air conditioner, microwave, cook top, and full bathroom with shower and toilet. Designed with maneuverability and lighter weight in mind for smaller trucks and tighter spots, less time is spent parking and more time riding. Built with the quality and standards people have come to expect in a Sundowner, it carries a 3 year hitch to bumper and 8 year structural warranty.

Horizon 6904 RS

LIVING QUARTERS



INTERIOR STANDARD EQUIPMENT

- 13,500 BTU a/c with heat strip
- Wood window frames
- Raised panel cabinet doors
- Overhead cabinets in kitchen area
- 3 cu. ft gas/electric refrigerator
- 2 Burner cook top with cover, range hood and exhaust fan with light
- Microwave
- Formica counter tops
- Single bowl kitchen sink
- TV antenna
- AM/FM radio, CD player with interior and exterior speakers
- Day/night shades
- Color coordinated valances
- Choice of vinyl flooring with carpeted bedroom
- Mattress
- Quilt and two matching pillows
- TV stand
- Wardrobe and linen closet
- Retractable shower door
- Towel rack, ring and toilet paper holder
- Toilet
- Power roof vent in bathroom
- Metal grab handle
- 19 gallon fresh water tank
- 12 volt demand water pump
- City water hook up
- 35 gallon black water tank
- 35 gallon gray water tank
- Sewer dump hose and storage compartment
- 2, 20 lb. propane tanks with automatic change over valve
- 6 gallon LP gas water heater
- Water drains and water heater bypass for easy winterizing
- Heavy duty 45 amp 12 volt power converter, battery charger
- 12 volt charge line to truck
- 12 volt battery disconnect switch
- Deep cycle battery
- 30 amp marine style 36' power cord lifeline with 12 amp adapter
- 120 volt kitchen and bathroom receptacles, GFI protected
- LP gas leak detector
- Smoke alarm and fire extinguisher
- Emergency exit windows in nose
- Tempered safety glass windows
- Full fiberglass R7 insulation in floors, sidewalls and ceiling
- Consumer protection seals
- Code approved in all 50 states

TRAILER STANDARD FEATURES

- 2 5/16" Gooseneck hitch, adjustable
- Slant load
- 2, 3, or 4 Horse
- 6' 9" Wide
- 7' Tall
- 39" Wide stalls
- All aluminum construction
- All aluminum floors
- Mill finish top half, extruded aluminum sides lower half
- Rubber torsion axles
- 4 Wheel electric brakes with safety breakaway
- Rear rubber bumper
- LED clearance and tail lights
- Spare tire and wheel
- Solid head and shoulder divider(s)
- Floor mats in horse area
- Drop down feed door with sliding window per stall
- 2 Air gaps with Plexiglas on rump side
- SunCoated™ kick panels slant wall, rump wall and rear doors
- Double rear doors with Plexiglas
- Pop-up vent per horse stall
- Dome light in horse area
- 1 Outside and 2 inside tie rings per stall
- Collapsible rear tack with saddle rack, tack hooks and light
- Center access door from horse area to living quarters

POPULAR OPTIONS

- Additional dome lights
- Load lights
- Aluminum face guard
- Rear ramp
- Electric motor assist on jack
- 7K Hydraulic jack
- Awning
- Hayrack
- Rumpside window package per model (window per stall on rump side, window in load side rear door, side access door, and SunCoat™ on headside)

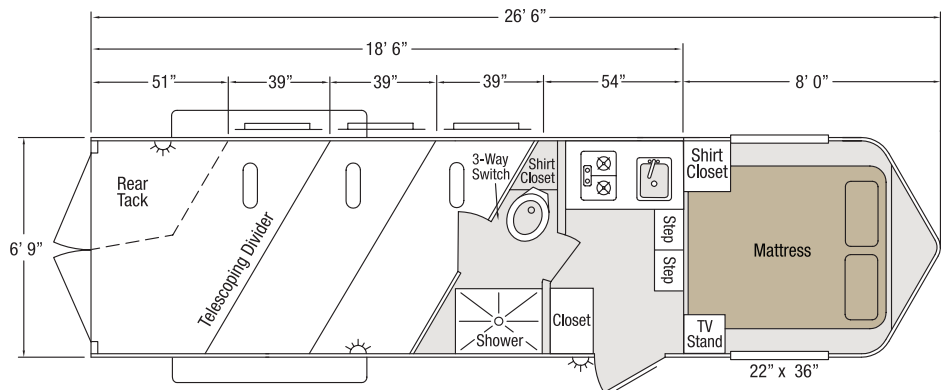

ALSO AVAILABLE IN 4 HORSE

All dimensions are approximate. Photos may show options. Due to constant product improvements, specifications, component parts, standard and optional equipment are subject to change without notice or obligation. Refer to standard and special features for specifics. See your dealer for warranty details. 2014 © Sundowner Trailers, Inc. (10-30-14)

SUNDOWNER TRAILERS, INC.

9805 OK Highway 48 South • Coleman, Oklahoma 73432-8523

800-438-4294 • www.sundownertrailer.com