

NEXT LEVEL STANDARDS AND OPTIONS

BODY AND FRAME CONSTRUCTION

Standard Features

- Alumaframe® Superstructure
- 8" I-Beam Frame
- Vinyl Exterior Graphics
- Smooth Metal .040 Sidewalls
- Fiberglass Front Cap
- S/O Lock Down Arms with Slide-Out Room Option
- 3/8" Foam Core, Thermal Barrier Laminated Sidewall Structure
- Prep For Spare Tire
- Two Tone Color Fender Skirts/Wraps
- 1-1/2" Steel Framed Sub-Floor
- Wide Body Axle
- 5/8" Sturdi-Wood Flooring
- 6-Steel Flush Mounted Tie-Downs – 5000 Lb. Capacity
- Polished Anodized Diamond Plate Cargo Wall Protector
- Laminated Bath Deck
- Aluminum Roof Structure with RV 2000 Exterior
- Vapor Barrier in Roof
- Hard Board Vinyl Ceiling
- Front Roof Rack and Ladder
- Triple Step
- Power Landing Jacks
- 5,200 Lb. Nev-R-Lube Triple Axles with Electric Brakes
- 15" Radial Tires
- Beaver Tail Floor
- 2500 Lb. Rated Ramp Door
- 95-1/4" Wide Rear Ramp Door
- Non-Skid Ramp Door Flooring
- Cam Lock Rear Door Locking System
- Stylized 15" Sport Wheels with Chrome Center Hub
- Wrap Storage Doors – Six (6)

Options

- Gel Coat Fiberglass Sidewalls
- Stabilizer Jacks (1-Pair Rear)
- Recessed Spare Tire with Sport Wheel
- Wheel Chocks (2)
- Enclosed Underbelly
- Shock Absorbers
- Chrome Rims – 4 Wheels
- Flip Over Transition Ramp
- Electric Winch – with Tether Remote

APPLIANCES

Standard Features

- 8 cu.ft. 2-Way Refrigerator with Brushed Nickel Insert Panel
- Microwave with Touch Control
- High-Output 3-Burner Range with Stove Cover
- Systems Monitor Panel on Range Hood
- Telephone Jacks in Kitchen and Bedroom Area

Options

- Built-In Safe
- Four 2-Way Portable Rechargeable Radios
- Pop-Up Hamper/Trash Can
- 20" Color TV with Remote Control in Living Room Area – TV Swivel Base Required
- 13" Color TV with Remote Control in Bedroom
- TV Swivel Base – Required for 20" TV Option
- Air Compressor
- Outside Cooking Grill with Quick Disconnect

INTERIORS

Standard Features

- Vintage Oak Cabinets
- Oak Flat Panel Cabinet Doors
- Brushed Nickel Cabinet Hardware
- Catches on All Interior Drawers
- Brushed Nickel Refrigerator Door
- Diamond Plate Slide-Out Room Fascia Insert with Trim Piece and Rosette
- Laminate Kitchen Countertop with Corian® Accent Edge – Galley and Lavatory
- Diamond Plate Galley and Lavatory Backsplash
- Built-In Kitchen Trash Can
- Silverware Tray
- Flat Panel Pocket Door
- TV Cabinet in Bedroom
- Toilet Tissue Holders
- Towel Rack in Stool Room
- Carpeting and Pad in Bedroom
- Utility Center by Entrance Door
- Linoleum in Kitchen, Bath and Entry
- O/H Cabinets with Additional Storage and Cargo Netting above Sofa
- Overhead Storage Attic above Kitchen
- Magazine Rack in Stool Room

Options

- Wood Choices: Light Maple
- Patent Pending Electric Magic Bed with Ladder-King Size with 2-24" Flush Mount Clothes Hangers
- Roll-Out Pantry with Cabinet with 3 Baskets
- Cargo Divider Wall with Door
- Surged Carpet for Cargo Area
- Kitchen Countertop Extension – Where Applicable

FURNITURE

Standard Features

- Side Queen Bed with Front Wardrobe
- Chest of Drawers with TV Shelf
- Polyethylene Indoor/Outdoor Table
- Two (2) 79" Roll-Over Sofas
- Bedspread
- Hardwood Headboard with Decorative Insert Panels

Options

- 40" x 60" Roll-Over Dinette
- Two (2) Barrel Chairs with Flip-Up Table ILO Dinette
- Queen Bed Slide-Out with Chest of Drawers and Overhead TV Cabinet
- Twin Beds with Wardrobes
- Bunk Beds with Wardrobes

ELECTRICAL SYSTEMS AND LIGHTS

Standard Features

- Digital 12V Linear Series AM/FM with CD-DVD Player Stereo with 6 Upgrade Speakers, 40 Watt Amp
- Two (2) Water-Resistant Exterior Speakers
- Wider Wall Switches
- Fluorescent Lighting in Kitchen
- 12V Incandescent Lights with Clear Lens
- Electrical Management System (30Amp/12V with 55 Amp Conv.)
- Porch Light
- Six (6) Docking Lights 12V: 2-Side and 2-Rear Recessed, 2-End of Cargo O/H Cabinets
- 120V Exterior Recept
- Center Blinking Light
- Disconnect and Battery Box
- Trunk Light
- Bathroom Bar Light
- Cable TV/DSS/VCR Ready with Video Box
- 12V Recept Located in Kitchen
- Wineguard® TV Antenna with Cable Box
- Dual Exterior Cable/Satellite Recept

NEXT LEVEL STANDARDS AND OPTIONS

Options

- One 12V Deep Cycle Battery with Disconnect
- Two 12V Deep Cycle Battery with Disconnect
- Solar Prep
- 50 Amp Electric Service
- Generator Prep – 20 Gallon Fuel Tank, Remote Switch with Hour Meter, Fuel Gauge
- 4.0 kW MicroQuiet Gas Onan® Generator with 20 Gallon Tank
- 5.5 kW Marquis Gold Gas Onan® Generator with 20 Gallon Tank
- Pump Station with 40 Gallon Tank, Timer Switch and Fuel Gauges in Utility Center

PLUMBING AND LP SYSTEMS

Standard Features

- Large Stainless Steel Kitchen Sink with Brushed Nickel Single Handle Pull-Out Faucet
- Demand Water System with Water Pump
- 10-Gallon LP Gas/Electric Water Heater with Electronic Ignition (DSI)
- Stainless Steel Bathroom Sink with Brushed Nickel Faucet
- Brushed Nickel Shower Fixtures
- Brushed Nickel Shower Hose and Head
- Medicine Cabinet with Mirror
- ABS Shower with One-Piece Surround and Curtain
- Water Management System with Bottom Drain – Includes Outside Shower
- Water Heater By-Pass Kit
- High-Profile Toilet
- Two 30 Lb. LP Tanks with Automatic Changeover and Cover
- Water Heater Switch inside Unit
- Spray-Away Sprayer with Hose
- Sewer Hose Storage with Hatch and Tube

Options

- ABS Shower with One-Piece Surround with Glass Door
- No-Fuss Flush

HEATING, VENTS AND AIR CONDITIONING

Standard Features

- One Carrier 13.5M BTU Air Conditioner, High Capacity with Remote
- 40M BTU Hydroflame Electronic Ignition Furnace
- Ducted Heating System
- Manual Roof Vent
- 12V Roof Vent in Bathroom
- Wire Prep and Ducting for 2nd A/C with Optional 50 Amp Service

Options

- 12V Roof Vent in Cargo/Rear Roof Locations
- Second Carrier 13.5M BTU, High Output A/C with Remote in Rear Cargo Area (Requires 50 Amp Service Opt.)
- 15.0M BTU Carrier A/C ILO 13.5M High Output with Remote
- Attic Fan with Thermostat and Rain Sensor with 2-Way Switch – Except Rear Cargo/Bathroom 1-Direction

WINDOWS, DOORS AND AWNINGS

Standard Features

- DarkTinted Radius Windows (with White Frame)
- Tinted Skylight in Bathroom
- 30" Radius Main Entrance Door with Anti-Skid Steps
- Window in Stool Room

Options

- Exclusive "Checkered Flag" Texturized Fabric Awning
- Patio Screen Room
- Bedroom Slide-Out Cover
- Swing-Out Entry Door Handle
- Rear Ramp Door Screen

WINDOW TREATMENTS

Standard Features

- Brushed Nickel Mini Blinds
- Padded Valances and Lambrequins Throughout

SAFETY FEATURES

Standard Features

- Fire Extinguisher – 10 Lb.
- Deadbolt Lock(s) on Entrance Door(s)
- 120V GFI Protected Outlets (Kitchen, Bath, Exterior)
- Breakaway Switch
- LP Gas Detector
- Smoke Detector
- Egress Window(s)
- Safety Glass



NEXT LEVEL FLOORPLANS

34CK

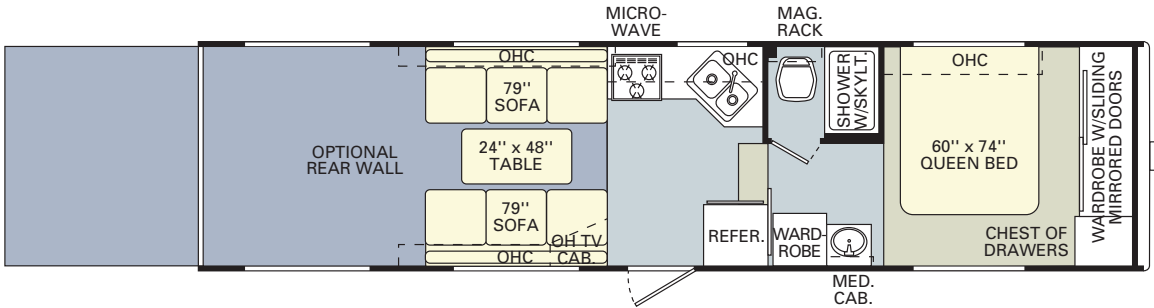

37CK

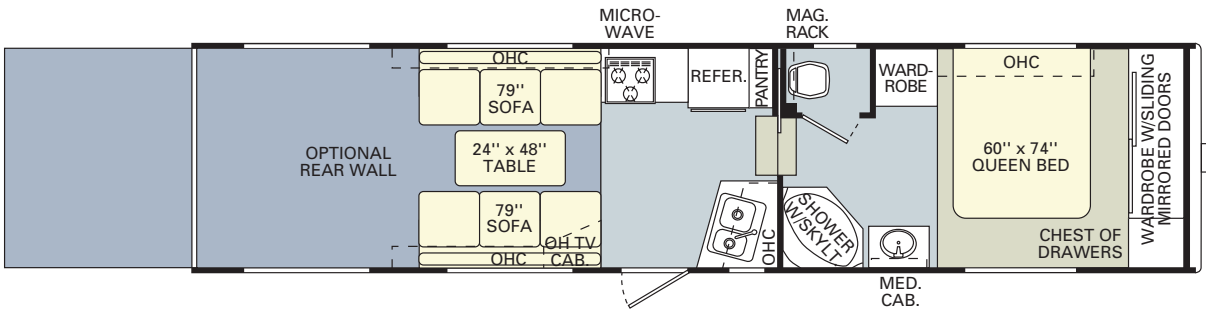

34CKS

